

**INTRODUCTION  
CERTIFICATES AND STANDARDS**

**AFTER PURCHASING SERVICES**

- QUALITY MANAGEMENT SYSTEM**
- MANAGEMENT RESPONSIBILITY
- INQUIRY & CONTRACT REVIEW
- DESIGN CONTROL
- DOCUMENT CONTROL
- PURCHASING CONTROL
- PRODUCT TRACEABILITY
- MANUFACTURING PROCESS CONTROL

- INSPECTION & TEST STATUS**
- INSPECTION DURING MANUFACTURING
- FINAL INSPECTION
- FINAL INSPECTION
- HYDRAULIC TEST
- 3TH PARTY INSPECTION

**PACKAGING, PRESARVATION & SHIPMENT  
TRAINING COURSES**

**PRODUCTS**

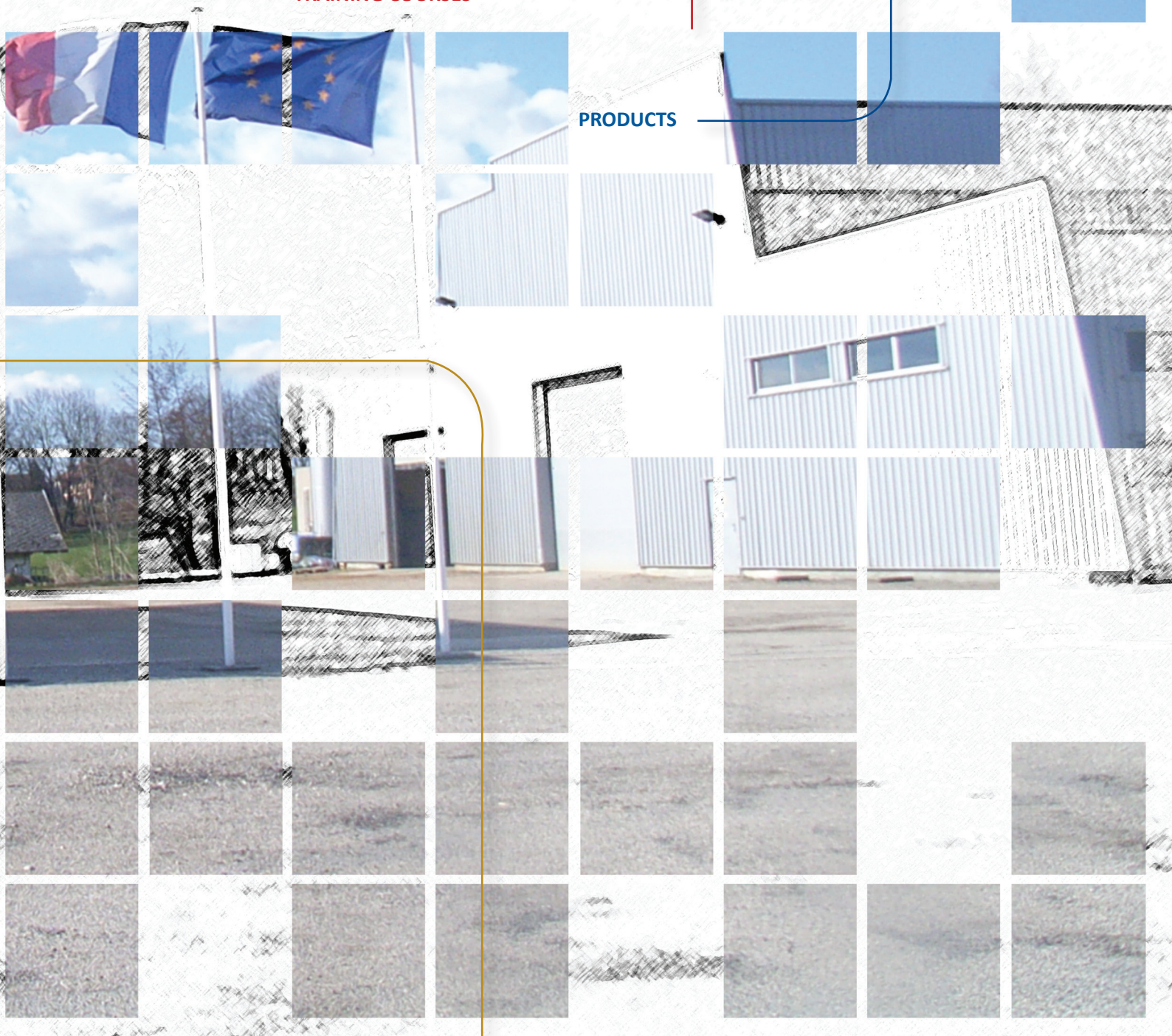

# HPL

## ENGINEERING

### CONCEPTION ET RÉALISATION D'ÉQUIPMENTS HYDROMECHANIQUES

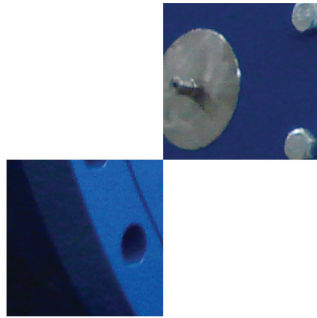

#### INTRODUCTION

HPL ENGINEERING Company is proud as a unique supplier of different type of valves and other applicable equipment in *dams, hydro-electric power-plants, pumping stations, water collections, filtrations and irrigation networks* in France.

HPL Engineering Co. is a family-based company – three generations of engineers from the LEZIER's for over 50 years.

Pierre LEZIER, the founder of HPL Engineering, has acquired over 50 years of experience in *hydro-mechanics* and is nationally and internationally recognized for the realization of numerous hydro-mechanical projects. He is the inventor and owner of several patents, including: *specific type of pressure reducer, an automatic shut-off safety valve, and an actuator for hollow jet valves.*

The capability of the company extends to design and manufacture of qualified and modern valves according to the international standards such as *DIN, ASME and CODA*. HPL Engineering Co. sets great store by top technology with the equivalent expenditure on research and development. The same applies to the qualification of our committed and open-minded staff.

A global sales organization guaranteeing in-depth advice for users ensures our presence and proximity to our customers all over the world. Our sales activities are concentrated on markets in Europe and increasingly, in Africa and Asia.

Providing the proper solutions for hydraulic parameters and improving the design of hydraulic system is the main consideration of our technical team

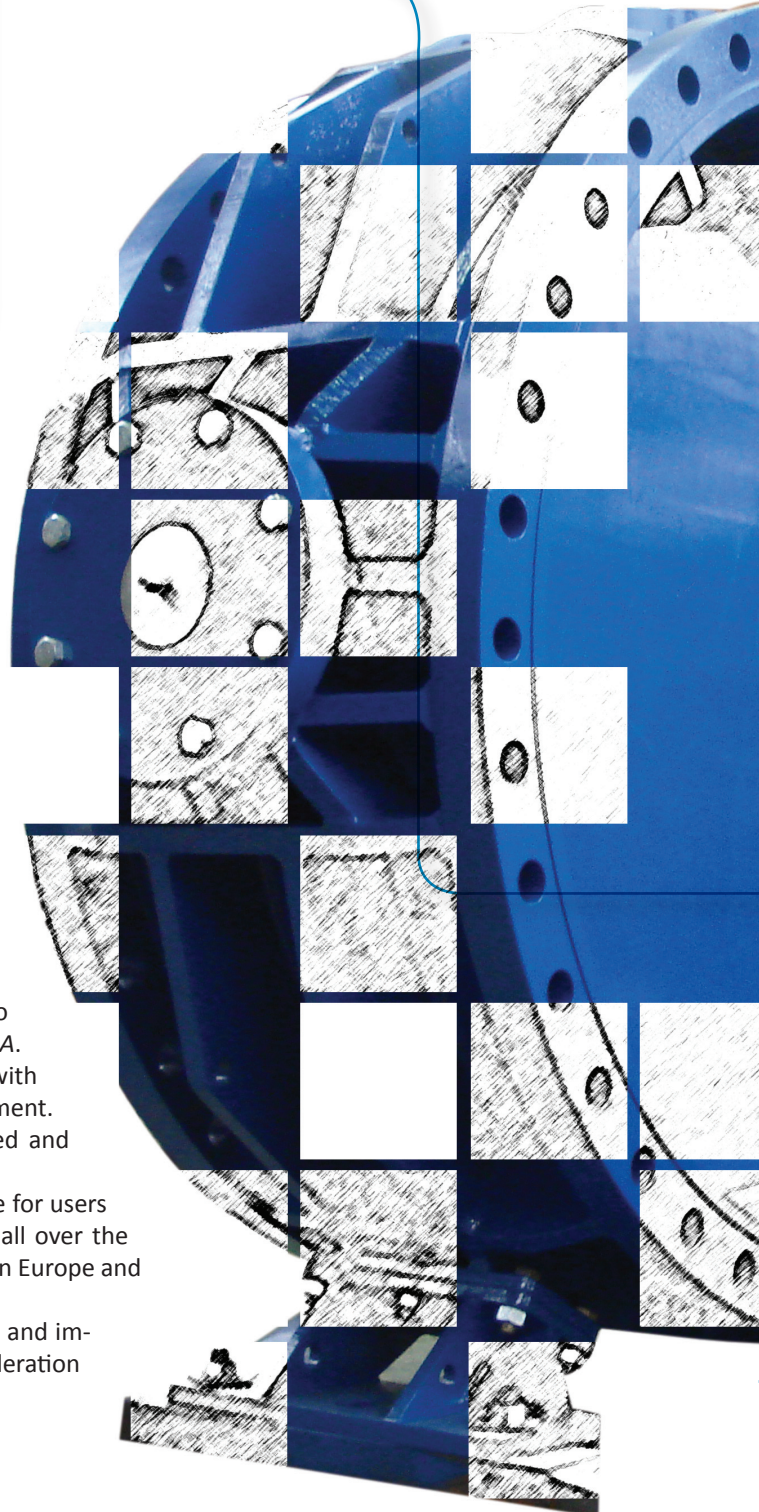

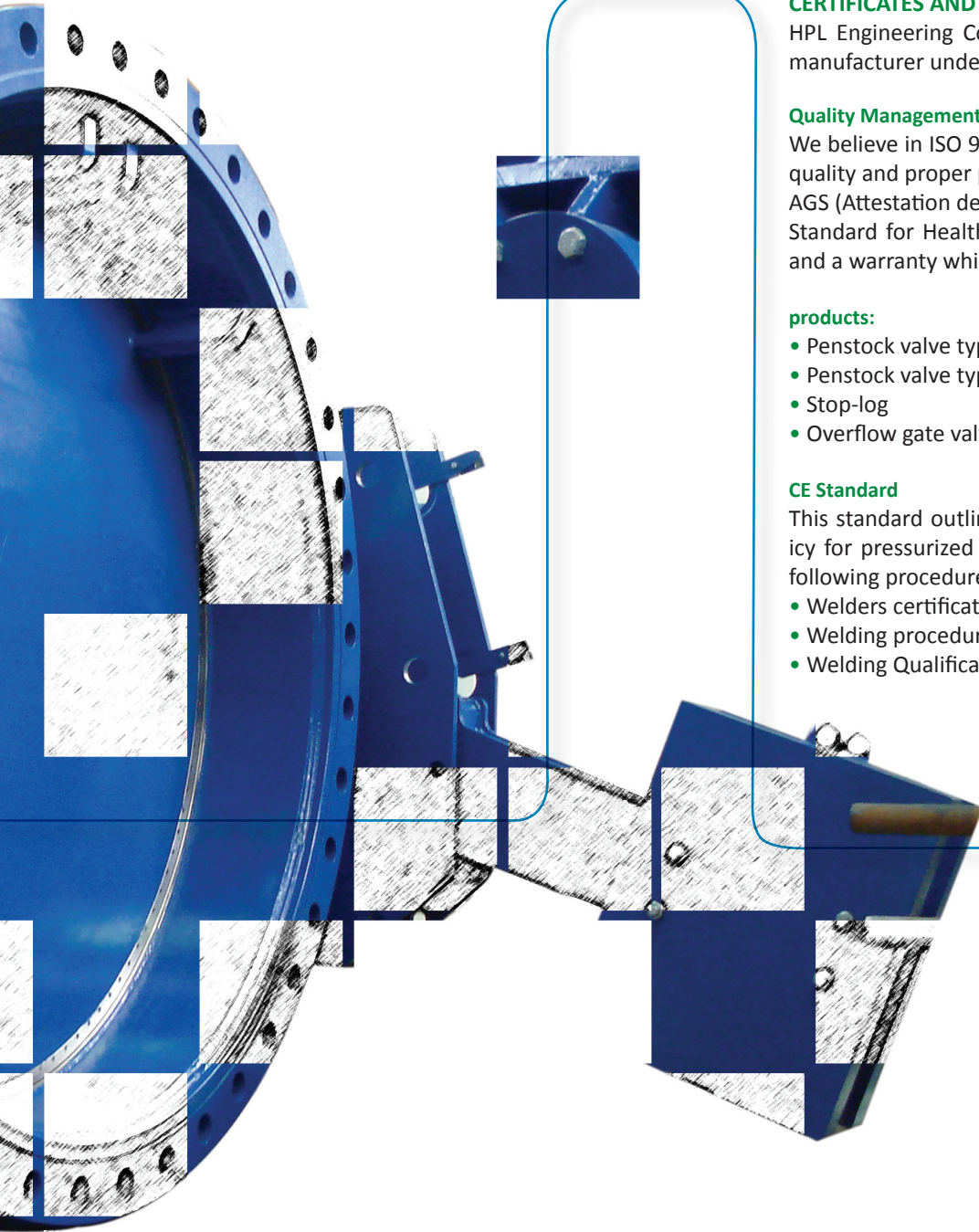

### **CERTIFICATES AND STANDARDS**

HPL Engineering Company is nominated as a manufacturer under following standards:

#### **Quality Management System - ISO 9001**

We believe in ISO 9001 as a way to insure high quality and proper procedures in organization. AGS (Attestation de Conformite Sanitaire) Standard for Health Certificate of Conformity, and a warranty which covers the following

#### **products:**

- Penstock valve type 100
- Penstock valve type 2
- Stop-log
- Overflow gate valve

#### **CE Standard**

This standard outlines Engineering Safety policy for pressurized equipment and covers the following procedures:

- Welders certificate
- Welding procedures
- Welding Qualification Procedure

### AFTER PURCHASING SERVICES

Achievement of higher quality in products and services is the main goal of HPL Engineering Company. For this reason all activities trend to the following aspects:

- During the purchasing process, from the client order to the shipment, all required information and technical supports will be provided.
- All products are in two-year warranty.
- New technical supports will be delivered continuously to professional customers.

### QUALITY MANAGEMENT SYSTEM

The following will explain our policy to meet the quality assurance in accordance with ISO 9001.

#### MANAGEMENT RESPONSIBILITY

According to achieve the high rank of quality in products and services, the quality control strategic plan have been issued by management. As a result, this system is divided into separated sections: One is internal auditing through all company's activities and other external auditing regarding to after sales servicing. Also, all quality control reports will be checked and monitored by managing director directly.

#### INQUIRY & CONTRACT REVIEW

HPL Engineering as a tailor made valve and equipment manufacturer, review any inquiries which are ordered to the company to meet the client requirements regarding the high rank of client satisfaction.

Design control will be done in two types; Standard design and special feature design

- All standard products are shown in technical catalogues to make easy access to select the required specification. First, these products are carried out as a prototype in several tests to specify the application/function related to the requirements. Next, the required documents and tests data are prepared to be handed over to client.
  - Special products in accordance with the client order, will be designed, modeled and simulated by finite element software. In addition, they would be tested by special hydraulic laboratories.



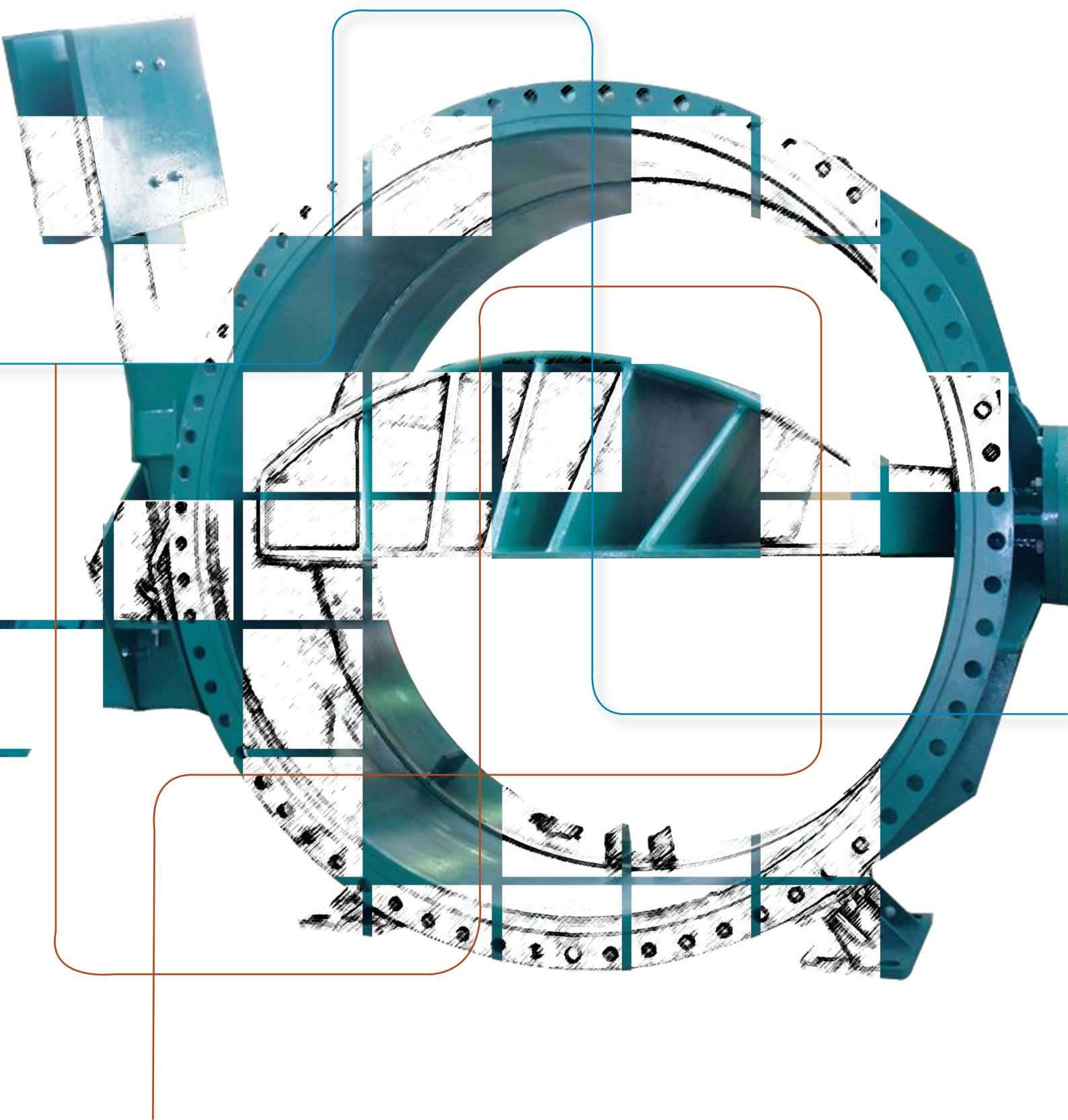

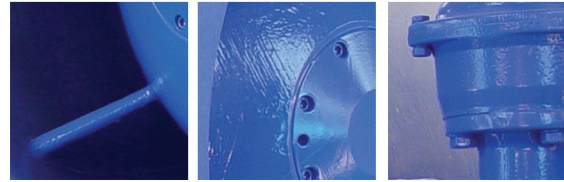

#### DOCUMENT CONTROL

Providing the proper documentation and dispatching all technical supports is one of the main responsibilities of our design team. These packages can be divided in two separate categories.

- Special document such as calculation sheets, drawings, as built drawings, quality control reports and certificates.
- General document include operation, maintenance and installation manuals.

#### PURCHASING CONTROL

HPL Engineering Co. is responsible for preparing, manufacturing and delivering the ordered products. Therefore, all miscellaneous devices which are provided by regional partners should be controlled to ensure that the compatibility with main products would be provided.

#### PRODUCT TRACEABILITY

According to DIN50049/EN10204, for higher traceability, all process such as documentation, supplying materials, manufacturing, delivering and also installation will be identified by standardize patch number.

#### MANUFACTURING PROCESS CONTROL

Our step-by-step quality control in various stages of manufacturing processes which starts from material acquisition and follows by cutting, assembling, welding, machining and coating, should be considered in construction plan. For this reason:

- Quality control procedures have been recorded in final books. Any corrective actions will be followed if needed.
- Random check is also carried out during process.

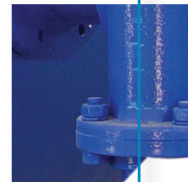



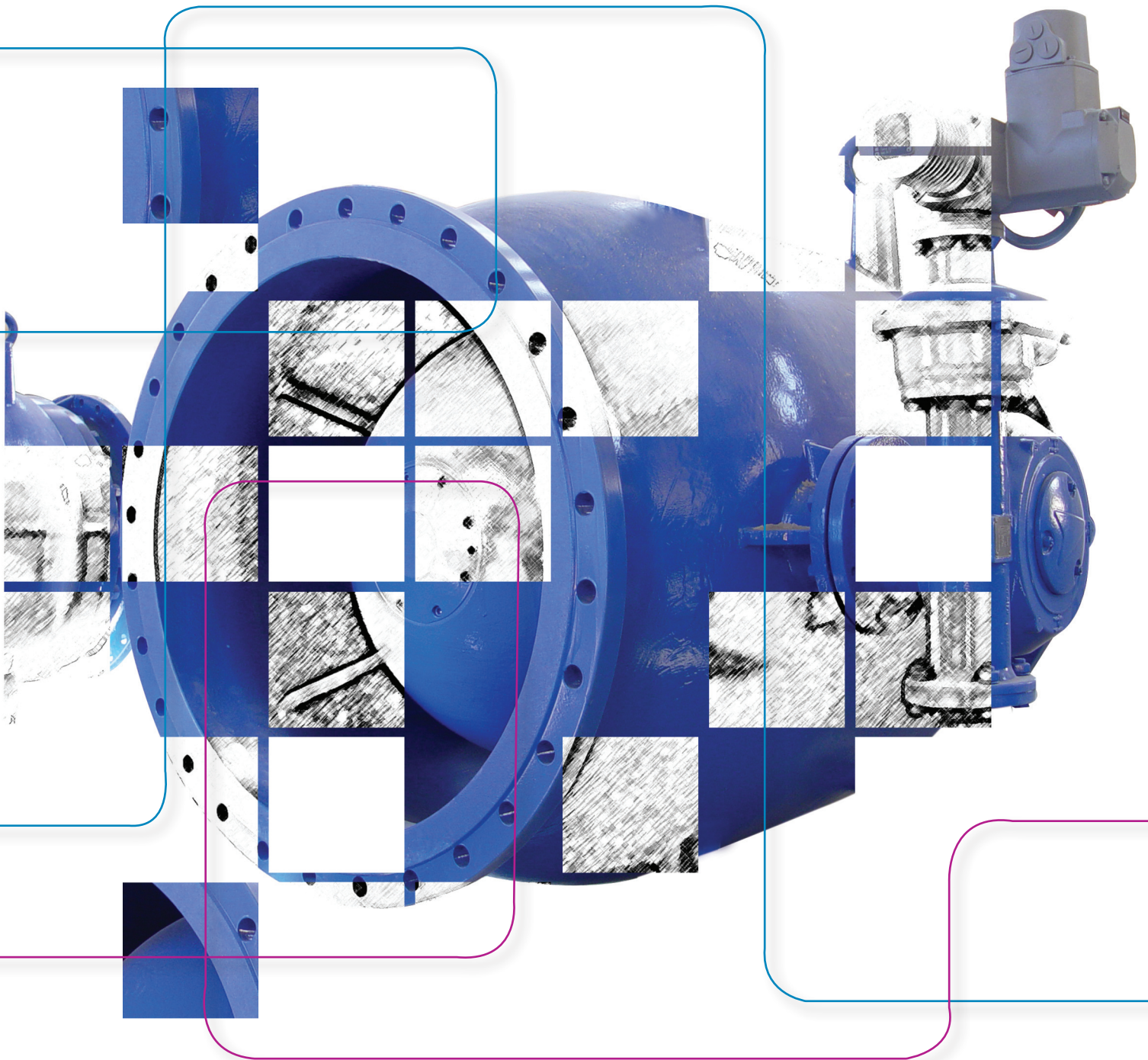

## INSPECTION & TEST STATUS

All inspection and check stages are contained on the check list, which accompanies the materials or parts all the way through the production process and serves as a constant indicator of the inspection status of the list. This process has defined in different stages.

## INSPECTION DURING MANUFACTURING

All required tests like visual, dimensional, Non destructive, destructive, lamination and any other coating tests will be done during manufacturing processes. Any other special tests would be carried out based on customer requests.

## FINAL INSPECTION

According to the requests, supplementary tests such as pressure test, leakage test and functional test will be carried out. All related reports will be sent after completion.

## HYDRAULIC TEST

Any modeling or special test related to tailor made products can be carried out by highly accredited laboratories in France.

## 3TH PARTY INSPECTION

HPL Engineering can provide any facilities for third party inspection before packaging and delivery.

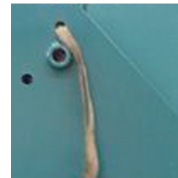

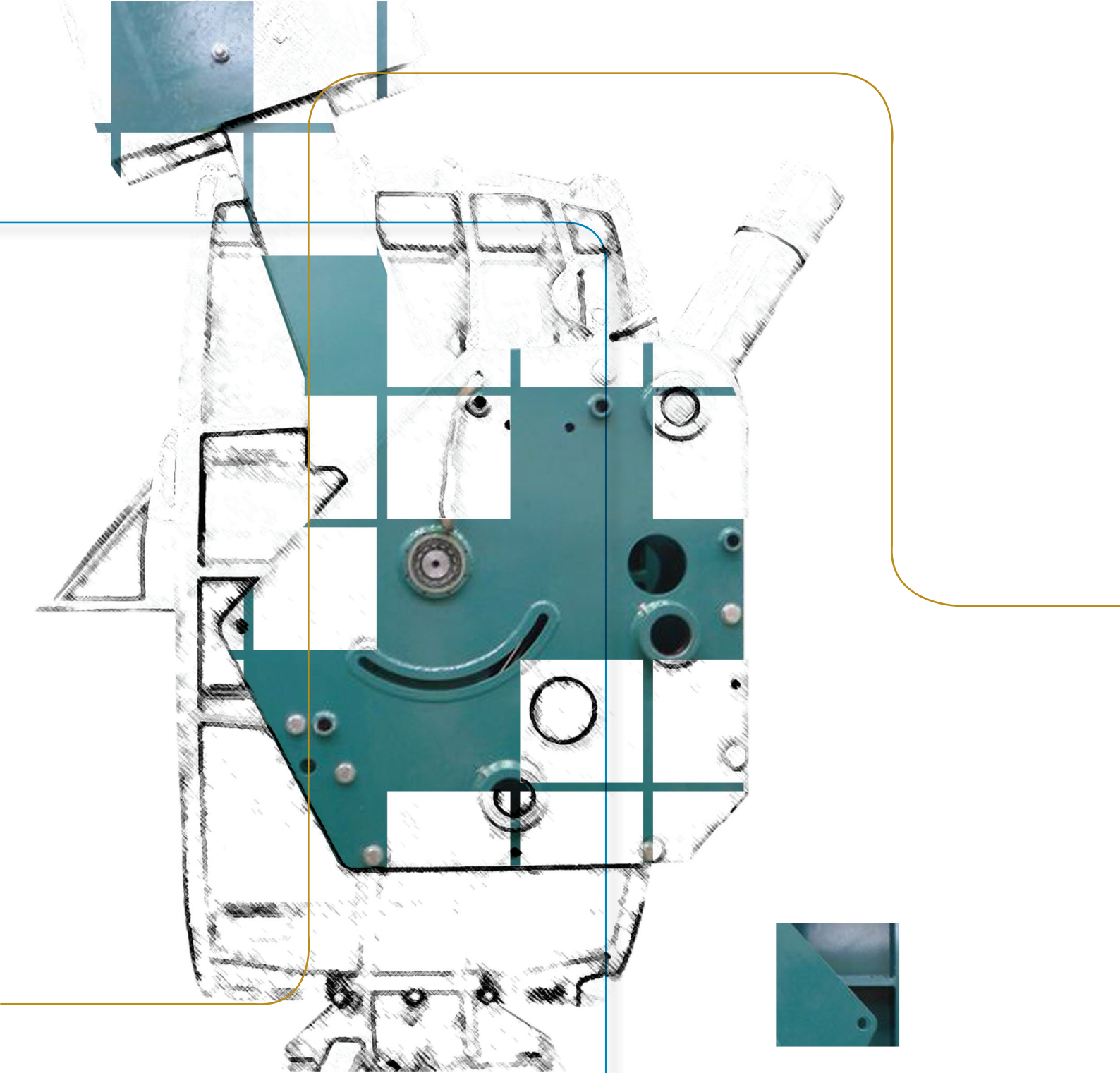

# HPL

ENGINEERING

CONCEPTION ET RÉALISATION D'ÉQUIPMENTS HYDROMÉCANIQUES

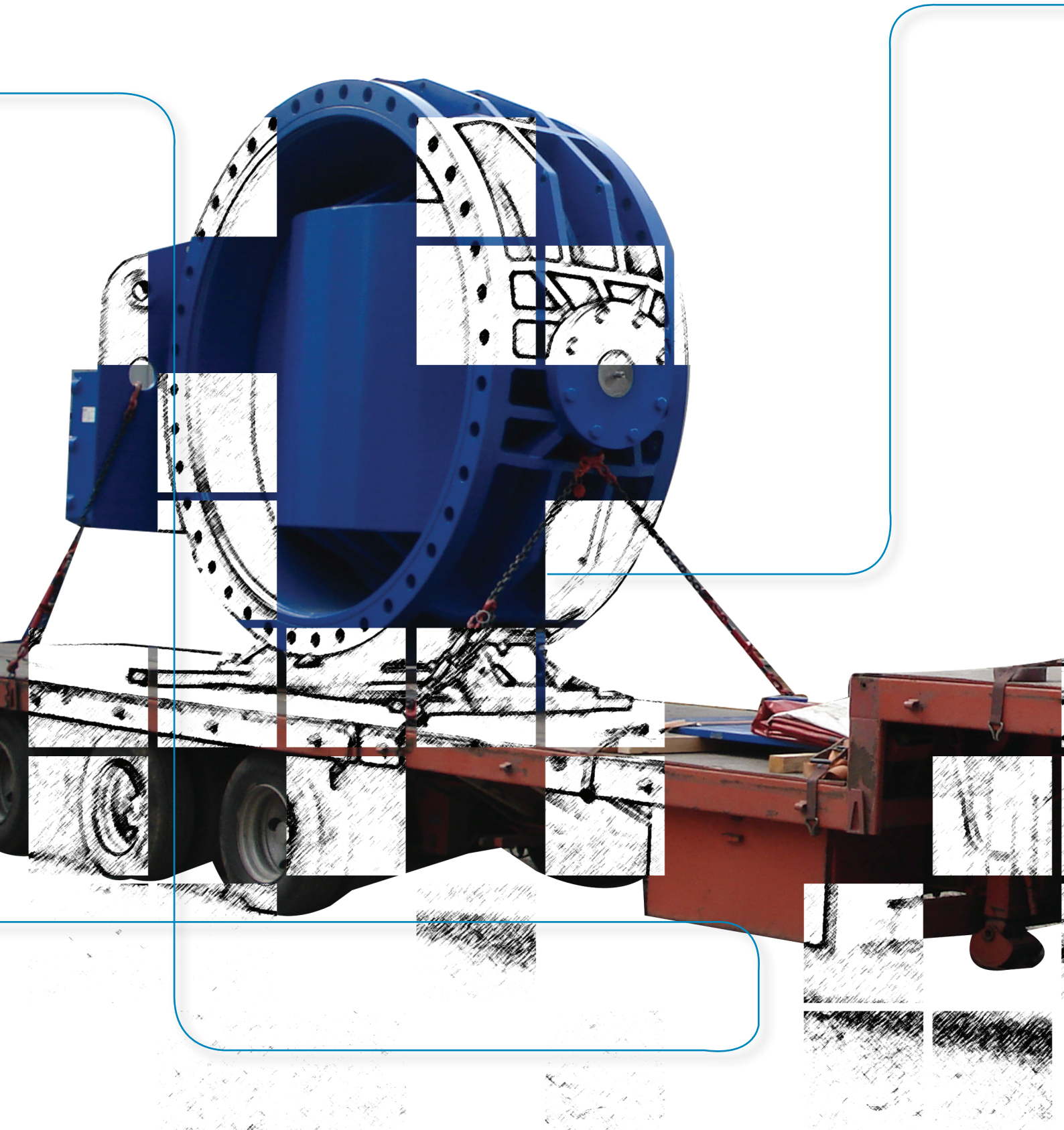



### **PACKAGING, PRESERVATION & SHIPMENT**

The necessary instructions are issued and activities are carried out to ensure that parts cannot be damaged, or confused during handling, preservation, and shipment within works, and that parts and products are readily available at all times. Moreover, spare parts and related manuals will also be added to the pack. Special packing would be carried out upon request.

### **TRAINING COURSES**

HPL Engineering Company persists in declining customer worries after sales processes. Therefore, as well as training courses for personnel in the company, holding regular training courses for its regional partners is the most important plan to ensure all after services are done in high quality degrees.

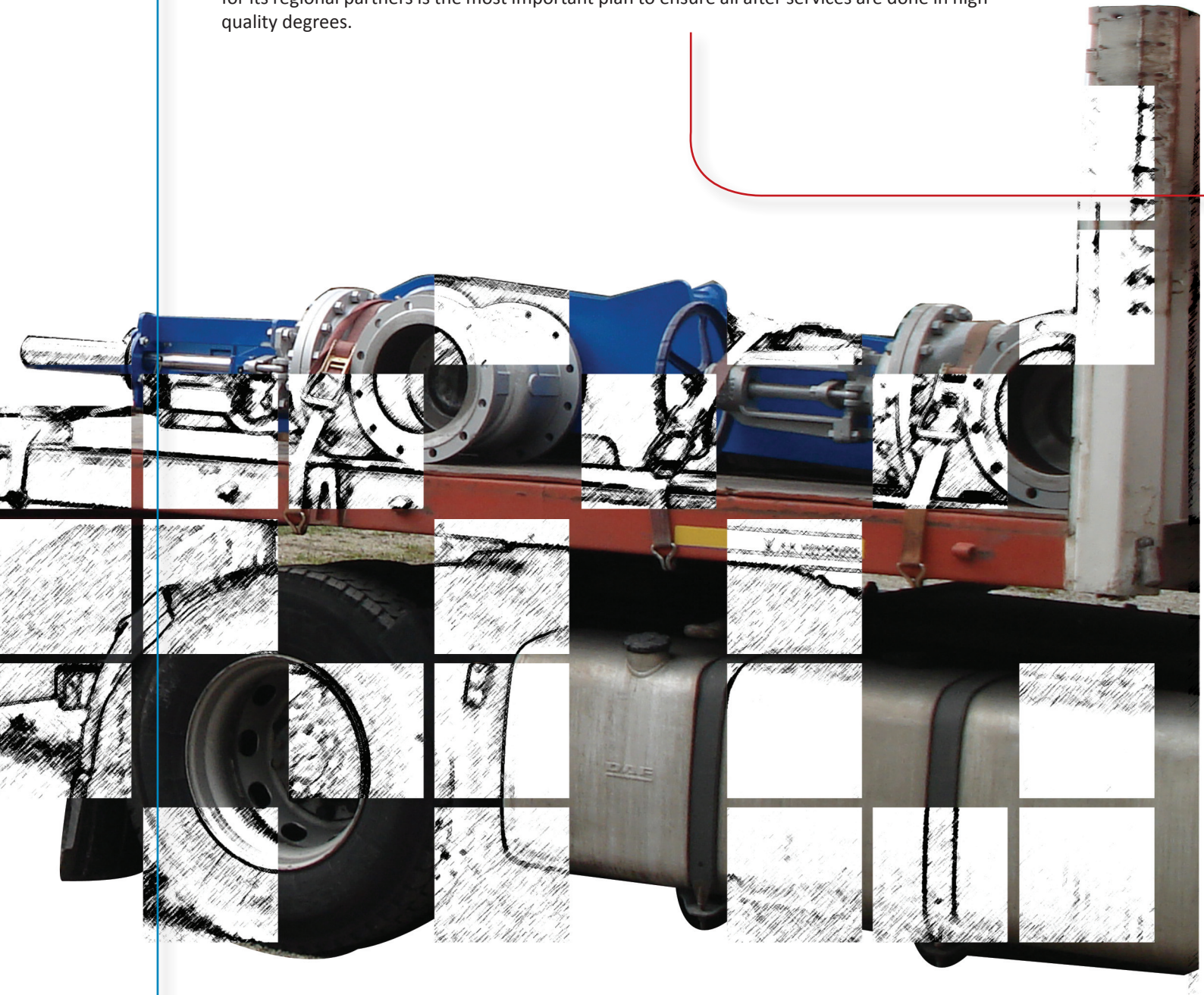

## PRODUCTS

The wide range of HPL Engineering products in water works engineering are illustrated as follow. Technical specifications of each product are given in the technical catalogues.

### ADJUSTABLE DIAPHRAGM

This product works as a flow regulating valve which is operated by the adjustable diaphragm in high pressure water lines. The range of production is in sizes of 300 mm to 2000 mm with working pressures of PN10 to PN100.



### FIXED DIAPHRAGM

This product is utilized as a pressure reducing device in pipelines and is produced in sizes of 300 mm to 2000 mm with working pressures of PN10 to PN100.

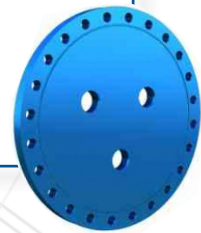

### BALL CHECK VALVE

It is recommended to use this product as a check valve in pumping station plants which pump water flow with high suspended particles. This product is manufactured in sizes of 150 mm to 1000 mm with working pressure of PN10.





#### **FLANGED CHECK VALVE**

This product is used in water and waste water projects with range of 300mm to 2000mm with working pressures of PN10 to PN100.

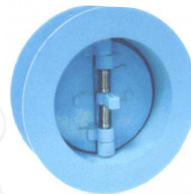

#### **SWING CHECK VALVE**

This type of valve is used in water and waste water projects as a guard to prevent devices from undesirable condition. It is produced in diameters of 300mm to 2000mm with working pressures of PN10 to PN16.

#### **LINEAR CHECK VALVE**

It is recommended to use this type of check valve in projects which is needed to utilize of valves for low pressure losses and also shut the valves in the shortest time. These valves in diameters of 200mm to 3000mm with working pressures of PN2.5 to PN100 are available.



#### **BUTTERFLY CHECK VALVE**

One of the most popular products in pumping station projects to prevent pumps from undesirable back pressure conditions is butterfly check valves. The range of production is in sizes of 300 mm to 2000 mm with working pressures of PN10 to PN100.

**PENSTOCK GATE  
EMBEDDED TYPE**

These gates are used for controlling the water flow in pressurized concrete ducts or canals. This type of gate is buried in concrete and manufactured in sizes of 200mm x 200mm to 2000mm x 2000mm. The larger sizes of these types of gates are produced on request.

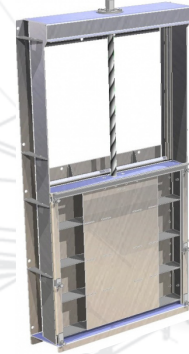
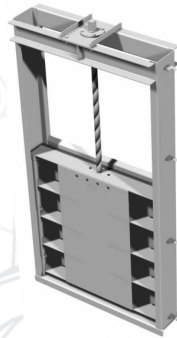

**PENSTOCK GATE  
BOLTED TYPE**

These gates are used for controlling the water flow in high pressure concrete ducts which are produced in sizes of 150mm x 150mm to 2000mm x 2000mm with a maximum working pressure 8 meter. The larger sizes of these gates are produced on request.



**OVERFLOW GATE VALVE**

These gates are capable of controlling water level in irrigation network structures. By opening the gate, the excessive flow in canals is discharged. This gate is manufactured in size of 200mm x 200mm to 2000mm x 2000mm. The larger sizes of these gates are produced on request.

**PENSTOCK GATE  
TYPE 150**

These gates are used for controlling the water flow in high pressure concrete ducts which are produced in sizes of 150mm x 150mm to 600mm x 600mm with a maximum working pressure 3m. The larger sizes of these gates are produced on request.





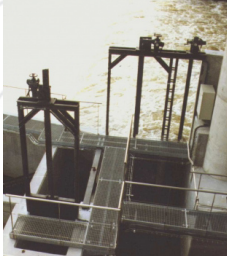

### STOP-LOG GATE

This gate is manufactured for controlling water flow in dam conduits. The range of production is in sizes from 200mmx200mm to 2000mmx2000mm and is also custom manufactured in bigger sizes.



### GATE VALVE

Gate valve is one of the popular products for using as a shut off valve in medium and high pressure conditions in the conduits and pipelines. This valve is manufactured in sizes of 300mm to 2000mm working pressures of PN10 to PN100.



### SOFT SEALING GATE VALVE

This valve is used for sectioning the pipes in water distribution lines and networks which is manufactured in working pressures up to PN25.

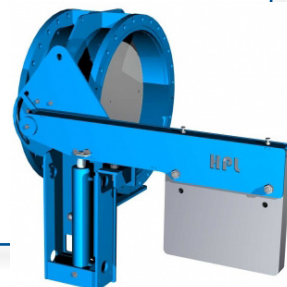

### BUTTERFLY VALVE with Single Acting Servo- Cylinder and Counter Weight

This type of Butterfly valve is commonly used as a Guard or Shut off valve in upstream sides of turbine or penstock in hydro-electric power plants. For convenient closing of disc, the valve actuator is equipped with counter weight. The range of production is in sizes of 300mm to 2000mm and with working pressures of PN10 to PN100.



### FLANGED BUTTERFLY VALVE

This type of Butterfly Valve is commonly used for sectioning in water transfer lines. This valve is manufactured in two types: **General Butterfly Valves** with working pressures up to PN64 and water flow velocity up to 5m/s. And **high speed butterfly valves** with working pressures higher than PN64 and water flow velocity higher than 5 m/s. Both types are manufactured based on dimensional standard ISO5752-series 14 or BS 5155.



### HYDRAULIC FLOAT VALVE

This valve is used for controlling water level in tanks with two type of mechanism: simple & automatic. Operating the valve is done with simple reaction mechanism in which installed in the tank. The sizes of 400mm to 1400mm with working pressures of PN10 to PN100 are available. The larger sizes of valves are constructed on request.



### FLOW CONTROL VALVE

This valve is mainly used for regulating processes which is equipped with pilot mechanism. So, it is not necessary to use electric actuators. This valve is manufactured up to PN40.

### NEEDLE VALVE

Needle valves are manufactured extensively for regulating pressure and discharge in pipelines. Needle valves are produced in range of PN10 to PN64 and with regarding the geometry base on standard NFE 29305 ranges 15 and ISO standard.





### HOWELL BUNGER VALVE

The popular valve for water energy dissipation at the end of pipeline is Howell Bunger valve. This valve is mainly used in Dams and Hydro-Electric Power-Plant. These valves are Tailor made, i.e. manufactured based on specifications provided by the customer (diameter, working pressure, chemical composition of water, working conditions and locations).



### EQUILIBRATED FLOAT VALVE

Regarding to adjusting water level in a tank, this type of valve is used for regulation at the end of the pipeline. High sensitivity of the buoyant mechanism makes to use of this type of valve for regulating of special projects. This valve is available in working pressures of PN2.5 to PN64.



### ACTUATED EQUILIBRATED VALVE

This valve is installed in the storage tanks or wells for water energy dissipation. This phenomenon cause to fill tanks or wells very smoothly. The range of production is in sizes of 300mm to 2400mm with working pressures of PN10 to PN40.



### AIR INLET VALVE

This valve is used for prevention of negative pressures and vacuum condition during water hammer in water pipelines. The sizes of 40mm to 600mm with working pressures of PN10 to PN64 are manufactured.

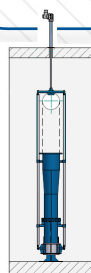
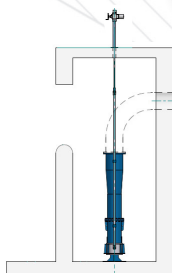

### VERTICAL SLEEVE VALVE

Vertical sleeve valve is used for water energy dissipation at the end of water flow pipelines in dams & hydro-electric Power-plan. This product is able to manufacture for large varieties of request.

## ROTARY DRUM FILTER

This type of filter is used for filtration in water or waste water purification/refinery plants. Rotary mechanism makes it possible for the drum to be thoroughly and easily cleaned. Filters with filtration net the range of 500 microns to 5mm is able to be manufactured.

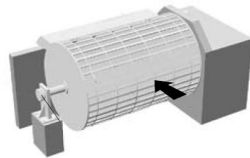

## VENTOUSE TRIPLE FUNCTION

This valve is used for:

- 1) Evacuation of air during filling operation
- 2) Air evacuation during continuous operation.
- 3) Intake air for prevention of negative pressure and vacuum condition.

The sizes of 50mm to 300mm with working pressures of PN10 to PN100 are available.

## SAFETY VALVE with Relieve function

Following situations are considered for selecting of this valve

- 1) Smooth dissipation of pressure waves generated by water hammer.
- 2) Preventing cavitation when the flow returns to the pumps.
- 3) Maintaining the pressure of pipeline in design condition during undesirable events.

This valve is manufactured in sizes of 65mm to 400mm with working pressures of PN10 to PN64.



## FIXED SCREEN STRAINER

This device includes a fixed, non-detachable and re-enforced steel net for pumping station inlets and available in sizes of 300mm to 2000mm and working pressures of PN10 to PN100.



## SELF-CLEANING STRAINER

This device includes detachable and cleanable steel net for installing at the pump suction line in water pumping station. It is available in sizes of 300mm to 2000mm and in working pressures of PN10 to PN100.

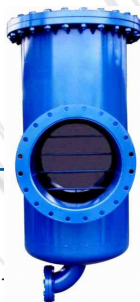



Equipment	Operation					
	Pumping Stations	Water Regulation	Irrigation Network	Filtration	Dam Valves	Hydro-power Plant
Adjustable Diaphragm						
Fixed Diaphragm						
Ball Check Valve						
Flanged Check Valve						
Butterfly Check Valve						
Swing Check Valve						
Linear Check Valve						
Penstock Gate - Embedded type						
Penstock Gate Type 150						
Bolted Penstock Gate						
Overflow Gate						
Stop-log Gate						
Gate Valve						
Soft Sealing Gate Valve						
Butterfly valve with single acting servo-cylinder and counterweight						
Flanged Butterfly valve						
Hydraulic Float Valve						
Flow Control Valve						
Needle Valve						
Howell Bunger Valve						
Vertical Sleeve Valve						
Actuated Equilibrated Valve						
Equilibrated Float Valve						
Safety Valve with Relieve Function						
Air Inlet Valve						
Ventouse Triple Function						
Fixed Screen Strainer						
Self Cleaning Strainer						
Rotary Drum Filter						

A L I A T E D



PROJECT NAME	COUNTRY	TYPE OF PRODUCT	QTY	DN	PN
SAINT ANDIENNE DE TINEE	FRANCE	BUTTERFLY VALVE	1	DN800	PN40
ATELIERS DU BRUISSIN	FRANCE	BUTTERFLY VALVE	1	DN800	PN40
SURPRESSEUR DE LA VALDEINE (EI)	FRANCE	BUTTERFLY VALVE	1	DN700	PN40
PUMPING STATION (SOGEA)	FRANCE	BUTTERFLY VALVE	1	DN600	PN40
PUMPING STATION (CISE)	FRANCE	BUTTERFLY VALVE	1	DN400	PN40
PUMPING STATION (CISE)	FRANCE	BUTTERFLY VALVE	1	DN200	PN40
TOURNON (CISE)	FRANCE	BUTTERFLY VALVE	1	DN600	PN40
GRPH ALPES (EDF)	FRANCE	BUTTERFLY VALVE	1	DN400	PN40
GRPH ALPES (EDF)	FRANCE	BUTTERFLY VALVE	1	DN250	PN40
SAUR	FRANCE	BUTTERFLY VALVE	1	DN350	PN40
SAUR	FRANCE	BUTTERFLY VALVE	1	DN200	PN40
SAUR	FRANCE	BUTTERFLY VALVE	1	DN250	PN40
SAUR	FRANCE	BUTTERFLY VALVE	1	DN200	PN40
PETAVIT	FRANCE	BUTTERFLY VALVE	1	DN600	PN40
PETAVIT	FRANCE	BUTTERFLY VALVE	1	DN350	PN40
SDEI	FRANCE	BUTTERFLY VALVE	1	DN150	PN40
EDF: REVIN HYDROELECTRIC POWERPLANT	FRANCE	BUTTERFLY VALVE	1	DN350	PN10
EDF: REVIN HYDROELECTRIC POWERPLANT	FRANCE	BUTTERFLY VALVE	1	DN600	PN16
EDF: GAMBSHEIM H.P.P	FRANCE	BUTTERFLY VALVE	2	DN1700	PN6
EDF: BAIGT HYDROELECTRIC POWERPLANT	FRANCE	BUTTERFLY VALVE	1	DN2000	PN6
EDF: BAIGT HYDROELECTRIC POWERPLANT	FRANCE	BUTTERFLY VALVE	1	DN1000	PN10
EDF: JOUSSEAU H.P.P	FRANCE	BUTTERFLY VALVE	1	DN2000	PN6
EDF: JOUSSEAU H.P.P	FRANCE	BUTTERFLY VALVE	1	DN1000	PN10
MOYEN CHELIFF PUMPING STATION	ALGERIA	BUTTERFLY VALVE	1	DN700	PN40
MOYEN CHELIFF PUMPING STATION	ALGERIA	BUTTERFLY VALVE	1	DN600	PN40
KSB	BELGUM	BUTTERFLY VALVE	1	DN800	PN40
KSB	BELGUM	BUTTERFLY VALVE	1	DN700	PN40
KSB	BELGUM	BUTTERFLY VALVE	1	DN600	PN40
KSB	BELGUM	BUTTERFLY VALVE	1	DN300	PN40
SIMENS	BELGUM	BUTTERFLY VALVE	1	DN500	PN40
SIMENS	BELGUM	BUTTERFLY VALVE	1	DN400	PN40
WUCHA	BULGARIA	BUTTERFLY VALVE	1	DN2700	PN10
DEVIN AND TESHEL	BULGARIA	BUTTERFLY VALVE	1	DN2500	PN16
DEVIN AND TESHEL	BULGARIA	BUTTERFLY VALVE	1	DN2600	PN10
SICILY:IRRIGATION NETWORK	ITALIA	BUTTERFLY VALVE	1	DN800	PN40

PROJECT NAME	COUNTRY	TYPE OF PRODUCT	QTY	DN	PN
SICILY:IRRIGATION NETWORK	ITALIA	BUTTERFLY VALVE	1	DN600	PN40
SICILY:IRRIGATION NETWORK	ITALIA	BUTTERFLY VALVE	1	DN400	PN40
SICILY:IRRIGATION NETWORK	ITALIA	BUTTERFLY VALVE	1	DN300	PN40
SARDINIA :irrigation network	ITALIA	BUTTERFLY VALVE	1	DN1000	PN40
SARDINIA :irrigation network	ITALIA	BUTTERFLY VALVE	1	DN800	PN40
CESANA AND PASSAREL H.P.P	ITALIA	BUTTERFLY VALVE	1	DN800	PN16
MARCO PHOSPHORE-OCP	MAROCCO	BUTTERFLY VALVE	1	DN2500	PN2.5
NEJAPA HYDROELECTRIC POWERPLANT	SALVADOR	BUTTERFLY VALVE	1	DN1000	PN40
HYDROELECTRIC POWERPLANT	SERI-LANKA	BUTTERFLY VALVE	1	DN600	PN25
AL SAFA	SYRIA	BUTTERFLY VALVE	1	DN1600	PN10
AL SAFA	SYRIA	BUTTERFLY VALVE	1	DN1400	PN10
AL SAFA	SYRIA	BUTTERFLY VALVE	1	DN1200	PN10
KALAN MALAYER DAM	IRAN	BUTTERFLY VALVE	1	DN1400	PN10
JAREH	IRAN	BUTTERFLY VALVE	2	DN1200	PN16
NARMASHIR DAM	IRAN	BUTTERFLY VALVE	1	DN1500	PN10
PETAVIT	FRANCE	GATE VALVE	1	DN1600	PN10
INGERIO	FRANCE	GATE VALVE	1	DN450	PN25
ONERA	FRANCE	GATE VALVE	1	DN600	PN10
EDF-REFRAIN DAM	FRANCE	GATE VALVE	1	DN500	PN10
EREMA	FRANCE	GATE VALVE	1	DN300	PN40
MECAMIDI	FRANCE	GATE VALVE	1	DN400	PN25
MOYEN CHELIFF PUMPING STATION	ALGERIA	GATE VALVE	1	DN700	PN10
MOYEN CHELIFF PUMPING STATION	ALGERIA	GATE VALVE	1	DN800	PN10
OTV- 10 DE RAMADAN	EGYPT	GATE VALVE	1	DN700	PN16
ADGE IRRIGATION NETWORK	ITALIA	GATE VALVE	1	DN150	PN64
ADGE IRRIGATION NETWORK	ITALIA	GATE VALVE	1	DN200	PN64
ADGE IRRIGATION NETWORK	ITALIA	GATE VALVE	1	DN300	PN40
ZUARA DESALINATION PLANT	LIBYA	GATE VALVE	1	DN1500	PN6
ZUARA DESALINATION PLANT	LIBYA	GATE VALVE	1	DN1500	PN10
BOU REGHREB DAM	MAROCCO	GATE VALVE	1	DN1000	PN16
BOUHOUDA DAM	MAROCCO	GATE VALVE	1	DN1500	PN16
BAB LOUTA DAM	MAROCCO	GATE VALVE	1	DN1500	PN6
FES IRRIGATION NETWORK	MAROCCO	GATE VALVE	1	DN600	PN10
OFICE CHERIFIN DES PHOSHPATES	MAROCCO	GATE VALVE	1	DN1500	PN6
OFICE CHERIFIN DES PHOSHPATES	MAROCCO	GATE VALVE	1	DN1000	PN6

PROJECT NAME	COUNTRY	TYPE OF PRODUCT	QTY	DN	PN
OTV- TANGER WATER TREATMENT PLANT	MAROCCO	GATE VALVE	1	DN1200	PN6
AIC- DRAA EL GRAGRA DAM	MAROCCO	GATE VALVE	1	DN800	PN10
INCINERATION PLANT	POLAND	GATE VALVE	1	DN450	PN25
OUED ZERGA DAM	TUNESIA	GATE VALVE	1	DN1100	PN10
SHAMILONIAN	IRAN	GATE VALVE	1	DN1200	PN10
SHAMILONIAN	IRAN	GATE VALVE	1	DN800	PN10
CHAMPAGNEY DAM	FRANCE	HOWELL BUNGER VALVE	1	DN400	PN10
BORT LES ORGUES DAM	FRANCE	HOWELL BUNGER VALVE	1	DN250	PN10
CASTALLANE DAM	FRANCE	HOWELL BUNGER VALVE	1	DN200	PN10
NOTRE DAM DE COMMIERS HPP	FRANCE	HOWELL BUNGER VALVE	1	DN700	PN10
BRETAGNE-EDF	FRANCE	HOWELL BUNGER VALVE	1	DN300	PN10
	BOLIVIA	HOWELL BUNGER VALVE	1	DN600	PN10
	BOLIVIA	HOWELL BUNGER VALVE	1	DN200	PN10
KINEH VARS DAM	IRAN	HOWELL BUNGER VALVE	1	DN500	PN10
NARMASHIR DAM	IRAN	HOWELL BUNGER VALVE	1	DN700	PN10
KALAN MALAYER DAM	IRAN	HOWELL BUNGER VALVE	1	DN300	PN10
KALAN MALAYER DAM	IRAN	HOWELL BUNGER VALVE	1	DN400	PN10
JAREH DAM	IRAN	HOWELL BUNGER VALVE	1	DN900	PN16
KANGIR DAM	IRAN	HOWELL BUNGER VALVE	1	DN600	PN10
BOUHOUDA DAM	MAROCCO	HOWELL BUNGER VALVE	1	DN1400	PN16
BOUHOUDA DAM	MAROCCO	HOWELL BUNGER VALVE	1	DN400	PN10
BOB BLOUTA DAM	MAROCCO	HOWELL BUNGER VALVE	1	DN400	PN10
EL GHRASS DAM	MAROCCO	HOWELL BUNGER VALVE	1	DN1400	PN16
SIDI SMAIL DAM	MAROCCO	HOWELL BUNGER VALVE	1	DN800	PN10
	TUNESIA	HOWELL BUNGER VALVE	1	DN1200	PN10
BAFT DAM	IRAN	NEEDLE VALVE	1	DN400	PN10
BAFT DAM	IRAN	NEEDLE VALVE	1	DN800	PN10
DAIK DAM	IRAN	NEEDLE VALVE	1	DN800	PN10
GARAN DAM	IRAN	NEEDLE VALVE	1	DN900	PN10
GARAN DAM	IRAN	NEEDLE VALVE	1	DN400	PN10
KALAN MALAYER DAM	IRAN	NEEDLE VALVE	1	DN300	PN10
BAGH KAL DAM	IRAN	VERTICAL SLEEVE VALVE	1	DN400	PN10







**HPL-ENGINEERING :**  
**HPL-ENGINEERING - ZA LASAGE-73330**  
**DOMESSIN – FRANCE**  
**Tel.: 33 (0) 4 76 31 26 70**  
**Fax: 33 (0) 4 76 31 26 79**  
**Email: [info@hpl-engineering.com](mailto:info@hpl-engineering.com)**